

PROJECT SUMMARY

42 MW GRAPHIC PACKAGING CHP PLANT **35% DESIGN AND CAPITAL COST ESTIMATING PROJECT**

PROJECT SUMMARY

Bridgestone Associates prepared a detailed feasibility study, detailed capital cost estimate and a 35% Design for a 42 MW Combined Heat and Power (CHP) plant for Graphic Packaging International Inc. for their paperboard manufacturing and consumer packaging plant in West Monroe, Louisiana. This natural gas fired CHP plant is based around a refurbished General Electric Frame 6B combustion turbine generator with a new Deltek (HRSG). The GE Frame 6 combustion turbine was installed previously at the 56 MW Cardinal Cogeneration Plant at Stanford University in Palo Alto, California. It operated there from 1986 until being shut down in March 2015. The combustion turbine, generator, switchgear, natural gas compressors, controls, and all the auxiliary equipment related to the combustion turbine was salvaged and removed by Bryan Power Generation and transported to West Monroe where it was reinstalled at the Graphic Packaging paper mill. It generates approximately 42 MW of electrical power and up to 250,000 lb/hr of 1,500 psig steam to drive existing steam turbines and for process use. The CHP plant construction started in July 2015 and unit start-up was achieved in December 2015. Bridgestone's 35% Design and Cost Estimating Project was completed in December 2014.



PROJECT STATISTICS

Client:	Graphic Packaging International Inc. / Bryan Power Generation Solutions
Project Type:	Natural gas fired combined heat and power (CHP) plant
Size:	42 MWe and 250,000 lb/hr 1,500 psig steam
Estimated Project Cost:	US\$39.0 million
Plant Location:	West Monroe, Louisiana, USA
Plant Elevation:	72 feet above sea level
Interconnection Voltage:	13.8 kV
Primary Fuel:	Natural gas
Back-up Fuel:	No. 2 Oil
Fuel Input:	495 MMBtu/hr HHV without duct burners; 595 MMBtu/hr HHV with duct burners
Plant Steam Conditions:	1,500 psig, 950 °F
Combustion Turbine:	1 x General Electric Frame 6B Model MS6001B Previously Installed at Cardinal Cogeneration, Stanford University, Palo Alto, CA, USA

Combustor Type:	Dry Low NOx
Emissions Controls:	Water Injection
HRSG:	Deltek 250,000 lb/hr, 1,600 psig, 975 °F - new
Duct Burners:	Coen
Steam Turbine:	Existing 20 MW 1,500/650 psig, 950 °F back-pressure steam turbine
Natural Gas Compressors:	2 x 400 hp, 4,160 V Ingersoll Rand Reciprocating Compressors
Thermal (Steam) Use:	1,500 psig Steam to Inlet of Existing 1,500/650 psig Back-pressure Steam Turbine. Steam from that turbine supplies another back-pressure steam turbine which provides steam to a 185 psig main steam header for process use within the paper mill

PROJECT DESCRIPTION

The project originally started in 2013 when Bridgestone Associates, through its on-going consulting arrangement with Bryan Power Generation Solutions of Colorado Springs, CO, was asked to prepare a detailed CHP feasibility study for Graphic Packaging at their West Monroe, LA mill. Graphic Packaging had already had a feasibility study prepared by another consulting engineering firm that was focused on the use of all new generating equipment. The capital costs estimated in that feasibility study resulted in a simple payback in excess of seven years, a payback period apparently not acceptable to Graphic Packaging. Bryan Power, a specialist in the re-use of pre-owned power generation equipment, was contracted to prepare the second feasibility study based on used equipment typically available in the market. This used equipment potentially could offer lower capital costs and a reduced simple payback.

The initial feasibility study prepared by Bridgestone Associates evaluated a number of prime mover alternatives including GE Frame 6, GE LM 2500, GE LM 6000, and Solar Titan 130 combustion turbines. Technical performance of all alternatives was evaluated on a seasonal (winter, spring/autumn, summer, and summer extreme) basis using GT-PRO. Capital and operations and maintenance costs were developed for both new and used equipment alternatives, to allow comparison between new and used and to allow comparison between the new cost estimates and current industry cost data. The result of this feasibility study was a recommendation to use a pre-owned GE Frame 6 combustion turbine. This, along with other used equipment components would result in an estimated capital cost of approximately \$33 – 35 million versus a new capital cost of \$55 – 60 million and a significantly reduced payback.

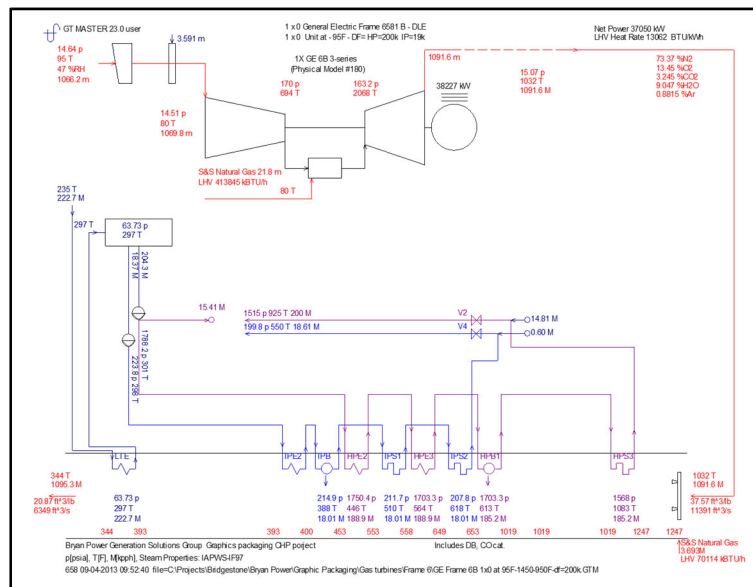

In late summer 2014 Bridgestone Associates and Bryan Power identified a GE Frame 6 unit that would suit the requirements of the Graphic Packaging project and presented this to Graphic Packaging. This unit was

in operation at Cardinal Cogeneration, a CHP plant operated by General Electric on behalf of Stanford University in Palo Alto, California. After approximately 30 years of operation, the plant was due to be turned over to Stanford University on March 31st, 2015, at which time the University planned to shut it down, decommission it and remove it in order to utilize the land for a new research building.

Bridgestone assisted Bryan Power in preparing a detailed survey, inventory and valuation of the equipment in Palo Alto. Bridgestone then assisted Bryan Power by providing technical support and other information to Bryan Power to allow Graphic Packaging to evaluate the equipment and its suitability. This included evaluating equipment performance and preparing heat balances using GT-PRO, and preparing a detailed economic model to allow economic performance and sensitivity analysis.

Once preliminary purchasing agreements had been executed between Graphic Packaging and Bryan Power, Bridgestone was asked to prepare a complete evaluation of the potential capital costs to allow Graphic Packaging management evaluation and final approval of the necessary capital allocation. The evaluation prepared by Bridgestone included the development of a complete 35% Design Study and a +/- 10% Capital Cost Estimate for the proposed plant.

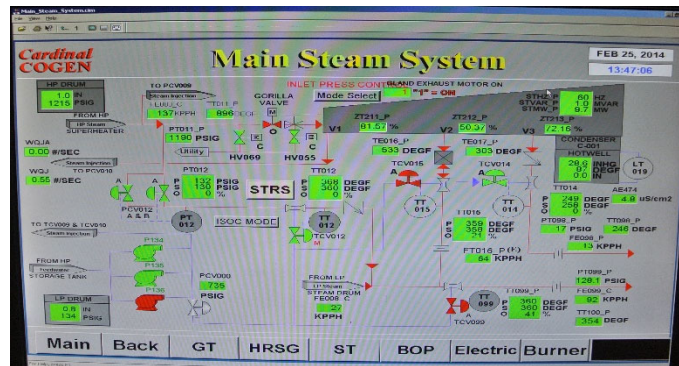

The 35% Design prepared by Bridgestone included analysis of subsurface conditions and a preliminary foundation design; design of high and low pressure steam interconnections approximately 800 feet into the mill’s boiler house; preliminary equipment selection and design of make-up water treatment equipment and supply system; preliminary equipment selection and design of condensate cooling and treatment equipment and supply system; preliminary equipment selection and design and layout of gas and oil supply piping systems; and identification of electrical interconnection requirements and equipment selection. The work also included development of a number of alternative layouts on the existing mill property and final selection of layout and equipment orientation.

As part of the deliverables of the 35% Design effort, Bridgestone prepared and delivered complete one-line electrical drawings, P&IDs, process flow diagrams. Following Graphic Packaging’s acceptance of these documents Bridgestone prepared the preliminary layout drawings, and equipment, motor and instrument lists. The Capital Cost Estimate included all major equipment and construction items and an assessment of the +/- percentage accuracy of each cost in order to be within the +/- 10% accuracy required. The Capital Cost Estimate was developed by Bridgestone’s team using Thermoflow’s PEACE program (interacting with Thermoflow GT-PRO and GT-MASTER), data from R.S. Means and other industry cost databases, budget cost estimates obtained from vendors and equipment suppliers, and past experience with similar projects, and included over 1,000 line items.

Throughout this 35% Design process, Bridgestone interacted with Graphic Packaging plant personnel to tailor the design to meet Graphic Packaging's corporate engineering and mill operations management's design requirements. These changed many times during this design process due to the interaction between corporate engineering and mill operations causing Bridgestone to have to make numerous changes in the design, often including re-working designs already completed.



The primary equipment evaluated in this 35% Design included the GE Frame 6 combustion turbine generator and all of its auxiliaries from Cardinal Cogeneration in Palo Alto. The suitability of the Vogt HRSG at the Cardinal Cogeneration plant was also evaluated to determine if it could be used in West Monroe. This unit weighed approximately one million pounds and was built with substantially increased structural steel to allow for seismic requirements in California (the Cardinal Cogeneration site at Stanford University is less than five miles from the San Andreas Fault line). While it was determined, with some modification, to be technically suitable, it was determined that the complexity and costs associated with its removal and transportation from the site in Palo Alto, and its refurbishment and reinstallation costs in West Monroe would be 50 – 60% or more of the costs of a new unit. Graphic Packaging therefore decided to purchase a new Deltek HRSG.

After evaluation of the capital costs and the benefits of the CHP plant, Graphic Packaging corporate management agreed to proceed with the project. In response to a request from Graphic Packaging, Bridgestone submitted a proposal for the Detailed Engineering of the plant. While Bridgestone's costs were understood to be very competitive and the previous work had received positive praise from corporate and mill engineering, regrettably this proposal was unsuccessful as another engineering firm with close high-level ties to Graphic Packaging management and local proximity was selected instead.

In May 2015 Bryan Power commenced salvage of the CHP equipment at Stanford. Bridgestone provided on-site Project Management and Technical Support throughout the dismantling, salvage and loading of all of the equipment. Bridgestone also was responsible for day-to-day interaction with on-site and off-site Graphic's Packaging personnel, personnel from the general contractor responsible for the complete site decommissioning, Stanford University Facilities personnel, Cardinal Cogeneration staff, and Bryan Power's salvage subcontractors.

The 35% Design and Detailed Capital Cost Estimate were completed in December 2014. The Cardinal Cogeneration plant was shut down in late March 2015 and equipment removal commenced in late April, 2015. The combustion turbine was removed and shipped in mid-June 2015. Civil construction started on the CHP plant site in July 2015 and the plant started generating power and steam in December 2015. Graphic Packaging saved approximately \$20 million by utilizing pre-owned equipment, reduced their overall schedule by approximately 9 months and shortened the project's simple payback by 3 - 4 years.